

Rovanco Copper Soldered System

For Temperatures to 210°F Above and Below Ground Applications. *

- Hot Water
- Chilled Water
- Fuel Oil
- LN2
- CO2
- Condensate
- Process Piping
- Refrigerant Piping

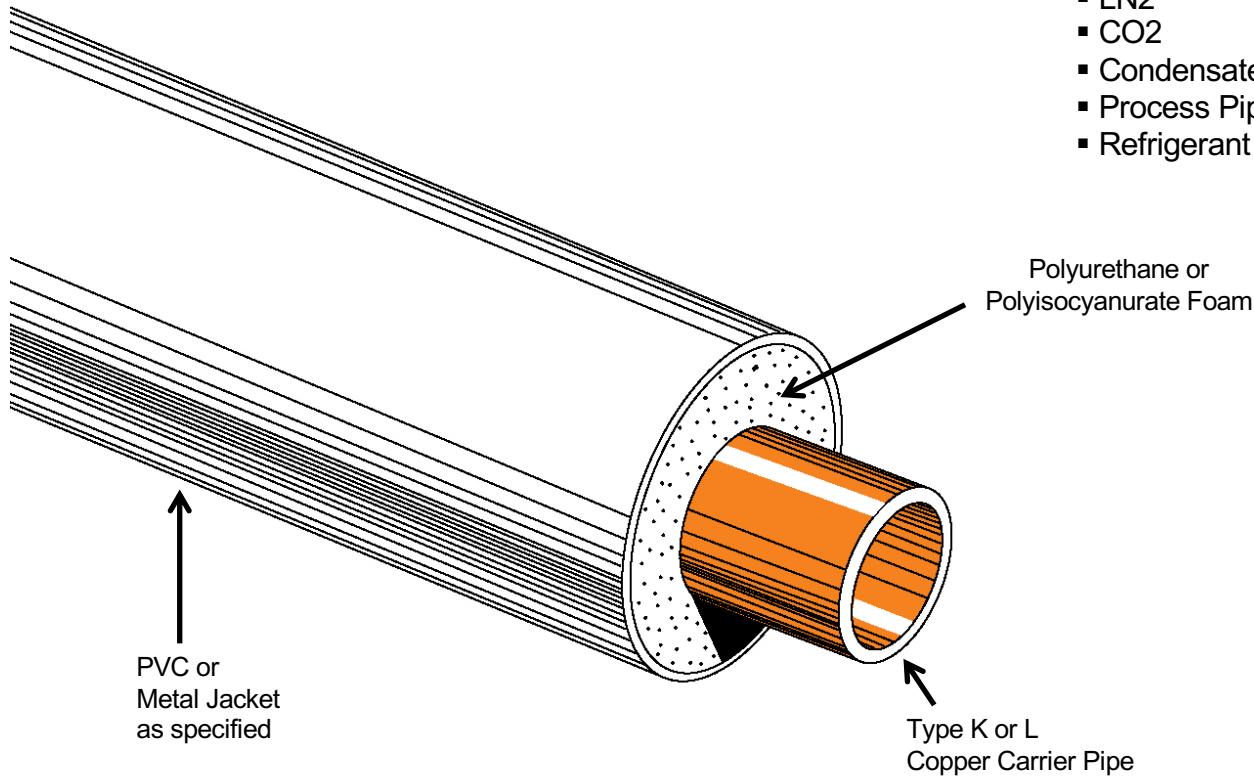

Rovanco's Copper Systems is designed for piping systems above or below ground suitable for inside or outside applications. Carrier pipe insulation is either a polyurethane or polyisocyanurate high quality foam, combined with a durable watertight jacket supplied in 20' lengths, means an economical, high-quality system.

Rovanco's Copper System is provided with jacketing of PVC or a spiral lock seam jacket of aluminum or galvanized steel which can be supported from the outside with maximum support spans. Fittings can be either insulated or factory fabricated as specified.

The Copper System comes complete with carrier pipe as specified, insulation of your choice, joint insulation materials and jacketing to make the installation completely watertight for applications of Process Fluids, hot water, chill water, etc.

To find out more about Rovanco's Copper Systems call or fax Rovanco at (815) 741-6700, Fax: (815) 741-4229, or visit our factory.

* For higher temperatures, consult factory.

This is a generic product datasheet and is not intended for submittal use.

SPECIFICATION DATA SHEET

Sweat Copper Piping System for Hot Water, Chilled Water, Fuel Oil, Ln2, Co2, Condensate, or Process Piping Applications

Carrier Pipe:

Type (K) or (L) Hard Drawn Copper Tubing conforming to ASTM B-88 in 20-foot lengths

Polyurethane Insulation:

Insulation shall be a polyurethane foam injected with one shot into the annular space between carrier pipe and jacket. Insulation shall be rigid, minimum 90% closed cell polyurethane with a minimum 2.0 lbs per foot³ density, compressive strength of 30 psi @ 75°F and a thermal conductivity K factor no higher than 0.180 @ 75°F per ASTM C-518. Maximum operating temperature of urethane foam shall not exceed 250°F.

Polyisocyanurate Insulation:

Insulation shall be a polyisocyanurate foam injected with one shot into the annular space between carrier pipe and jacket. Insulation shall be rigid, >90% closed cell polyisocyanurate with a minimum 2.0 lbs per foot³ density, compressive strength of 30 psi @ 75°F, a thermal conductivity K factor no higher than 0.121 @ 75°F per ASTM C-518 and an E84 25/50 passive fire resistance rating. Maximum continuous operating temperature of polyisocyanurate foam shall not exceed 300°F.

Also available in a 400°F polyisocyanurate foam.

Jacketing Material for Below Ground:

High-impact, seamless Polyvinylchloride (PVC) Class 12454-B compound conforming to ASTM 1784, Type 1, Grade 1, No FRP jacketing will be allowed. Minimum jacket thickness shall be in accordance with Table 1

Table 1.

Nominal Pipe Size in inches	Nominal Insul. Thickness in inches	Jacket Size in inches	PVC Jacket Thickness in Mils
½"	1.69	4	60
¾"	1.57	4	60
1"	1.44	4	60
1-¼"	1.82	6	70
1-½"	1.93	6	70
2"	1.94	6	70
2-½"	1.68	6	70
3"	1.43	6	70
4"	1.94	8	80

* The above is for HVAC applications, consult factory for information on cryogenic services and alternate jacket materials.

Joining Method:

Straight lengths of pipe will be joined by solder connection

Fittings and Field Joints:

All fittings will be wrought copper in conformance with job specifications and will be insulated and jacketed with materials supplied by the systems supplier and as per manufacturers standard procedures.

End Seals:

Each length of pre-insulated pipe will be fitted with a watertight mastic end seal at jacket and pipe surfaces. All field cuts will be sealed with a field applied end seals.

Anchors:

All pipe shall be anchored per system supplier's recommendations.

Backfill (If below ground):

Should be tamped compactly in place so as to assure a stable surface. No rock should be used in the first foot of backfill. 24 inches, top of pipe to grade, of compacted fill shall meet H-20 Highway loading.

Manufacturer's Assistance:

Rovanco will provide a field service man on-site to properly train the installing personnel in all phases of installation (if required).

Approved Vendors:

Copper Pipe System by Rovanco, Joliet, Illinois or approved, ISO Certified, equal. Any alternate supplier must submit their technical data to the engineer ten days prior to bid date to be approved in writing as an equal.

cc #06012023

Copyright 2023 – Rovanco's products are covered by various U.S. patents. Rovanco & Insul-8 are federally registered trademarks.

Contact Rovanco® for the name of your local Representative

20535 S.E. Frontage Road • Joliet, Illinois 60431 • (815) 741-6700

Website: www.rovanco.com • E-mail: marketing@rovanco.com

This is a generic product datasheet and is not intended for submittal use.