

# SECON-X®

Flexible stainless steel pipe system  
for gas stations, DEF and above ground fuel installations



**Double-wall flexible pipe for automotive fuels including ethanol, biodiesel and blends, marine, jet fuels and DEF**

## System advantages

- flexible, double-wall
- impermeable and safe from corrosion
- fast and easy to install
- environmentally safe
- the most cost effective metallic pipe

## General Description

SECON-X® is designed as an integrated primary/secondary pipe for fuel and DEF installations. Fast and easy installation without welding and minimum downtime on retrofits are only some of the major advantages of SECON-X®. SECON-X® is made in "endless" lengths, which eliminates the need for intermediate connections between beginning and end. Even distances beyond 1000 ft. can be covered with one single pipe.

## Construction

SECON-X® is a flexible pipe system with a stainless steel primary pipe capable of being tested and even monitored (underground installations only) for leaks. The SECON-X® double wall pipe system consists of a helically corrugated stainless steel primary pipe and a PA/LDPE secondary containment pipe. Helical channels are formed by the geometry of the primary pipe around the circumference, aided by longitudinal channels in the secondary pipe. Both extend over the entire length of the pipe. These longitudinal channels between the primary and secondary pipe provide the necessary annular space for the safe and contained flow of leaking product along and within the integral pipe.

The SECON-X® stainless steel primary pipe is not only corrosion resistant against all currently used, and most likely future fuels, but also prevents permeation. The fact that the pipe is made from 316L stainless steel eliminates the need for any additional cathodic protection.



## Sizes and Pressure ratings

Available sizes: 1", 1 1/2", 2" and 3"

Max. operating pressure: 145 PSIG /10.0 bar (except 3") or to full vacuum. The operating temperature range is -13 °F to +122 °F.

## Connection method

The SECON-X® end fitting is made of 316L stainless steel with fuel resistant elastomeric seals for both the primary and the secondary pipe. It is equipped with a test port for testing and monitoring. The end fitting is easy to assemble, requiring only common tools.

The end fitting is available with the following terminations:

- Thread (NPT, BSP)
- EZ-Fit

## Installation

SECON-X® is available in coils of the required lengths. The corrugated primary pipe gives this pipe extraordinary good bendability for ease of installation. SECON-X® can easily be cut to the required lengths on site and – where necessary – bent at very tight radii. Unlike with plastic piping there is virtually no recoil once bent. A feature that makes the contractor's job a lot easier and faster, and also saves money, too.



### SECON-X® end fitting

Available in NPT, BSP, EZ-Fit

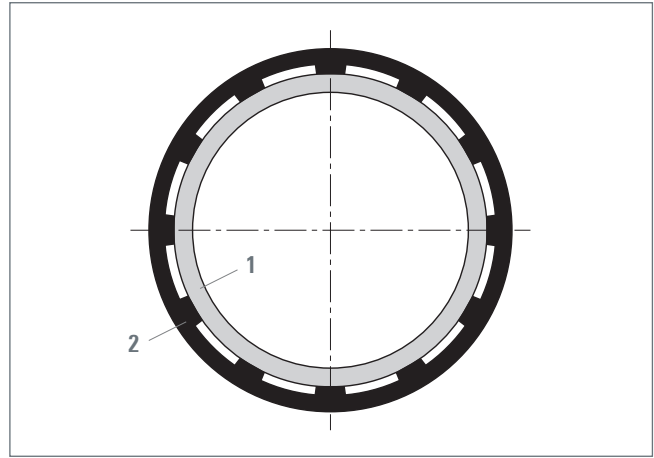

### SECON-X® construction

- 1 Corrugated stainless steel primary pipe
- 2 Internally fluted PA/LDPE jacket

### Technical data of SECON-X® pipes

Item	SECON-X®	SEC 1"	SEC 1 ½"	SEC 2"	SEC 3"
Pipe size		1"	1 ½"	2"	3"
Material	<ul style="list-style-type: none"> <li>• primary pipe: stainless steel 316L</li> <li>• secondary pipe: PA/LDPE</li> </ul>	•	•	•	•
Max. operating pressure (PSIG / bar)		145 / 10	145 / 10	145 / 10	50 / 3.5
Secondary containment pipe	<ul style="list-style-type: none"> <li>• closed (PSIG / bar)</li> <li>• open (PSIG / bar)</li> </ul>	50 / 3.5	50 / 3.5	5 / 0.35	5 / 0.35
Nominal ID (inch / mm)		1" / 25	1 ½" / 40	2" / 50	4" / 100
Dimensions	<ul style="list-style-type: none"> <li>• internal diameter (inch / mm)</li> <li>• external diameter (inch / mm)</li> </ul>	1.2 / 30	1.9 / 48	2.4 / 60	3.9 / 98
Volume	<ul style="list-style-type: none"> <li>• volume primary pipe (gal/ft) / (l/m)</li> <li>• volume interstitial (gal/ft) / (l/m)</li> </ul>	0.06 / 0.8	0.16 / 2.0	0.24 / 3.0	0.67 / 8.4
Min. bending radius	• with bending machine (inch / mm)	18 / 450	24 / 600	30 / 750	41 / 1050
Weight (lb/ft) / (kg/m)		0.52 / 0.78	1.18 / 1.76	1.3 / 1.94	3.15 / 4.7
Available service (per UL)	<ul style="list-style-type: none"> <li>• open</li> <li>• closed</li> </ul>	•	•	•	•
Leak monitoring	<ul style="list-style-type: none"> <li>• vacuum (PSI / bar)</li> <li>• pressure up to (PSIG / bar)</li> </ul>	-8.7 / -0.6	-8.7 / -0.6	-8.7 / -0.6	-8.7 / -0.6
		50 / 3.5	50 / 3.5	5 / 0.35	5 / 0.35

All technical data subject to change.



**BRUGG Rohrsysteme GmbH**  
 Adolf-Oesterheld-Straße 31  
 D-31515 Wunstorf  
 phone +49 (0)5031 170-0  
 fax +49 (0)5031 170-170  
 info@brugg.de  
 www.brugg.de

**BRUGG Pipesystems, LLC**  
 P.O. Box 1836  
 Rome, GA 30162-1836  
 phone +1 (706) 235 5606  
 fax +1 (706) 235 6035  
 pipesystems.na@brugg.com  
 www.pipesystems.com

A company of the BRUGG Group

**BRUGG** PIPESYSTEMS  
 Flexible solutions