

# SECON-X<sup>®</sup>

## Fuel Piping for Gas Stations and DEF

Installation Instructions



# Installation instructions

## Table of contents

SEC 6.101	Open and closed Secondary Containment Piping System Data sheet, End fitting
SEC 6.103	Installation Instructions Installing SECON-X®
SEC 6.104	Open and closed Secondary Containment Piping System Installation Instructions End Fitting
SEC 6.106	Open and closed Secondary Containment Piping System Start of Operation and Maintenance

Terms and Conditions



## IMPORTANT INFORMATION – FOLLOW ALL INSTRUCTIONS



### SAFETY

This safety alert symbol indicates an important safety message. When this symbol is visible, be alert to the possibility of personal injury.

### CAUTION

This pipe may carry hazardous material and/or operate at a hazardous pressure level; therefore, it is imperative that the instructions in this manual are followed to avoid serious personal injury or property damage. In any event, improper installation can cause injury or damage. Installers should read and follow all cautions and warnings to avoid personal injury. Also, observe general safety practices with all saws, tools, etc. to avoid personal injury. Wear protective clothing when necessary. Make sure work surfaces are clean and stable.



### Pipe and End fittings

Use only OEM fittings, follow installation and assembly instructions.



### Safety Precautions

SECON-X® Pipe Systems shall not be liable under any warranty, contract, or in tort, for any damage to equipment, pipe, or other personal property due to failure to follow the procedures and comply with the precautions set forth.

# End fitting with male thread

Open and closed Secondary Containment Piping System – Data sheet 1



**Loading, unloading and storing:**

Protect pipe and fittings from point-loading or impact damage at all times. Keep fittings dry.

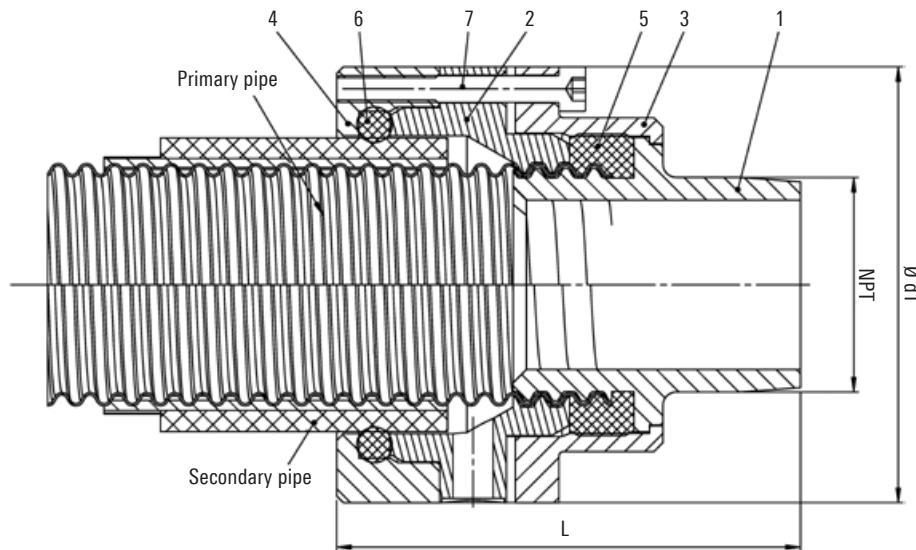

**After transport:**

Check pipe and fittings for damage. Do not use damaged units.



**Installation:**

Assemble end fittings only in visible areas.

Pos.	Qty.	Specification	Material grade
1	1	Threaded connector	316L or 316Ti
2	1	Thrust ring	316L or 316Ti
3	1	Pressure ring	316L or 316Ti
4	1	Seal chamber ring	316L or 316Ti
5	1	Primary seal	ECO; Hardness 55 +- Shore; Jäger Gummi: Type 5060-50
6	1	O ring	ECO; Hardness 55 +- Shore; Jäger Gummi: Type 5060-50
7	4	Screws M6 ISO 4762 M6	Stainless steel

Type	Thread NPT inch	d1 mm inch	L mm inch	Max. fitting torque lbft	Article No. NPT
SEC 1"	1"	76 3.0	91 3.6	7.3	701 102 10
SEC 1 ½"	1 ½"	98 3.9	104 4.4	18.4	701 103 10

# End fitting with male thread

Open Secondary Containment Piping System – Data sheet 1



**Loading, unloading and storing:**

Protect pipe and fittings from point-loading or impact damage at all times. Keep fittings dry.

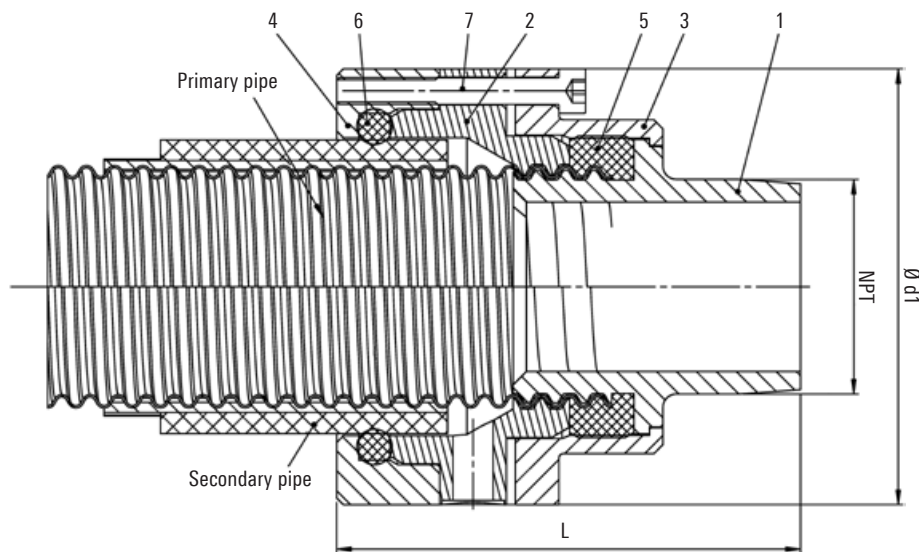

**After transport:**

Check pipe and fittings for damage. Do not use damaged units.



**Installation:**

Assemble end fittings only in visible areas.

Pos.	Qty.	Specification	Material grade
1	1	Threaded connector	316L or 316Ti
2	1	Thrust ring	316L or 316Ti
3	1	Pressure ring	316L or 316Ti
4	1	Seal chamber ring	316L or 316Ti
5	1	Primary seal	ECO; Hardness 55 +- Shore; Jäger Gummi: Type 5060-50
6	1	O ring	ECO; Hardness 55 +- Shore; Jäger Gummi: Type 5060-50
7	4	Screws M6 ISO 4762 M6	Stainless steel

Type	Thread NPT inch	d1 mm inch	L mm inch	Max. fitting torque lbft	Article No. NPT
SEC 2"	2"	109 4.3	112 4.4	18.4	701 104 10
SEC 3"	3"	156 6.1	154 6.1	18.4	701 105 10

# End fitting with EZ-Fit

Open and closed Secondary Containment Piping System – Data sheet 1



**Loading, unloading and storing:**

Protect pipe and fittings from point-loading or impact damage at all times. Keep fittings dry.

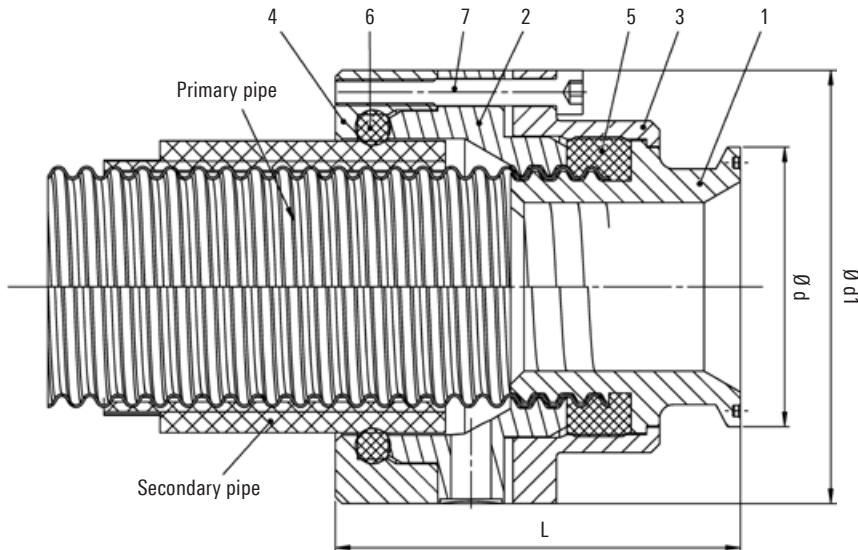

**After transport:**

Check pipe and fittings for damage. Do not use damaged units.



**Installation:**

Assemble end fittings only in visible areas.

Pos.	Qty.	Specification	Material grade
1	1	EZ-Fit Connector	316L or 316Ti
2	1	Thrust ring	316L or 316Ti
3	1	Pressure ring	316L or 316Ti
4	1	Seal chamber ring	316L or 316Ti
5	1	Primary seal	ECO; Hardness 55 +- Shore; Jäger Gummi: Type 5060-50
6	1	O ring	ECO; Hardness 55 +- Shore; Jäger Gummi: Type 5060-50
7	4	Screws M6 ISO 4762 M6	Stainless steel

Type	Connector	d	d1	L	Max. fitting torque	Article No. EZ-fit
		mm	mm	mm		
		inch	inch	inch	lbft	
SEC 1"	1"	43	76	87	7.3	701 102 12
		1.7	3.0	3.4		
SEC 1 1/2"	2"	63	98	92	18.4	701 103 12
		2.5	3.9	3.6		

# End fitting with EZ-Fit

## Open Secondary Containment Piping System – Data sheet 1



**Loading, unloading and storing:**

Protect pipe and fittings from point-loading or impact damage at all times. Keep fittings dry.

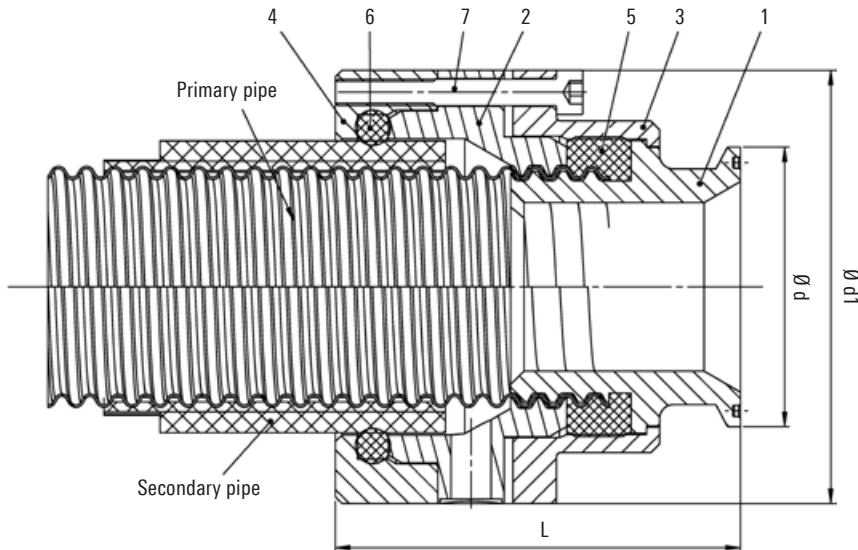

**After transport:**

Check pipe and fittings for damage. Do not use damaged units.



**Installation:**

Assemble end fittings only in visible areas.

Pos.	Qty.	Specification	Material grade
1	1	EZ-Fit Connector	316L or 316Ti
2	1	Thrust ring	316L or 316Ti
3	1	Pressure ring	316L or 316Ti
4	1	Seal chamber ring	316L or 316Ti
5	1	Primary seal	ECO; Hardness 55 +- Shore; Jäger Gummi: Type 5060-50
6	1	O ring	ECO; Hardness 55 +- Shore; Jäger Gummi: Type 5060-50
7	4	Screws M6 ISO 4762 M6	Stainless steel

Type	Connector	d	d1	L	Max. fitting torque	Article No. EZ-fit
		mm	mm	mm		
		inch	inch	inch	lbft	
SEC 2"	2"	63	109	94	18.4	701 104 12
		2.5	4.3	3.7		
SEC 3"	3"	91	156	133	18.4	701 105 12
		3.6	6.1	5.2		

# Secondary Containment Piping System

Data sheet



**Loading, unloading and storing:**

Protect pipe and fittings from point-loading or impact damage at all times. Keep fittings dry.

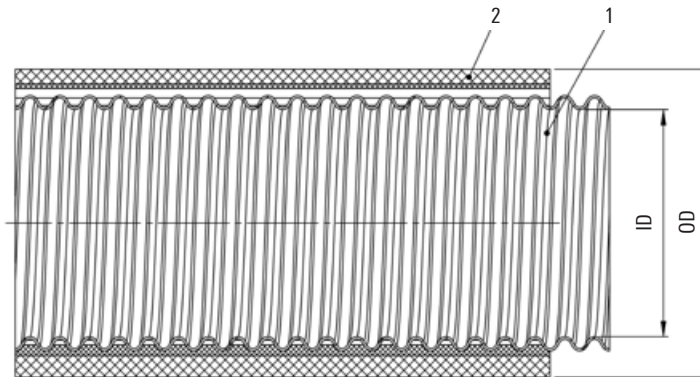

**After transport:**

Check pipe and fittings for damage. Do not use damaged units.



**Installation:**

Assemble end fittings only in visible areas.

Pos.	Qty.	Specification	Material grade
1	1	Primary Pipe	316L or 316Ti
2	1	Secondary Pipe	PE-LE6025 PA-6; Grilon F 50

Type	ID mm inch	OD mm inch	Max. Operating Pressure PSI	Article No.
SEC 1"	30 1.2	44 1.7	145	700 211 91
SEC 1 1/2"	49 1.9	66 2.6	145	700 213 91
SEC 2"	60 2.4	75 2.9	145	700 214 91
SEC 3"	98 3.9	119 4.7	50	700 216 91

# Installation instructions

## Installing SECON-X®

### Unreeling the pipe



The piping shall only be installed by qualified personnel (certified by the manufacturer). The use of non-qualified personnel or any deviations from these recommended procedures could result in damage or leakage of the system.

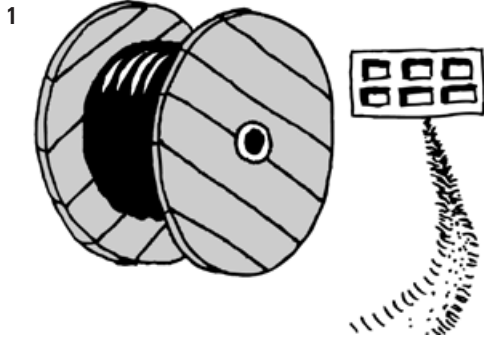

You will have received our SECON-X® Pipe in a coil or on a cable reel. Ideally, you should position the drum in such a way that the pipe can be unreeled directly from the drum.



Secure reel from falling or rolling.  
Storage temperature  $\leq 120$  deg F.

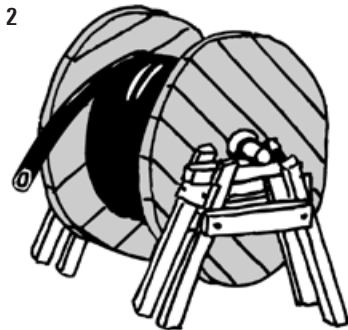

Use a reel stand to unreele the pipe.

Use a 3 inch steel pipe as axle (see figure 3).



The shrink cap at the end of the pipe should not be removed in order to prevent dirt or moisture from entering the primary or the secondary pipe when laying pipe.



While handling the pipe, always make sure to use appropriate safety shoes and gloves.

3

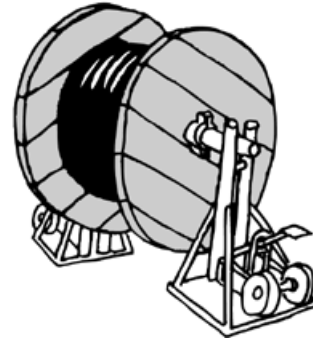

Hydraulic jacks simplify the work. These are worth purchasing if you are frequently involved in laying SECON-X®.

4

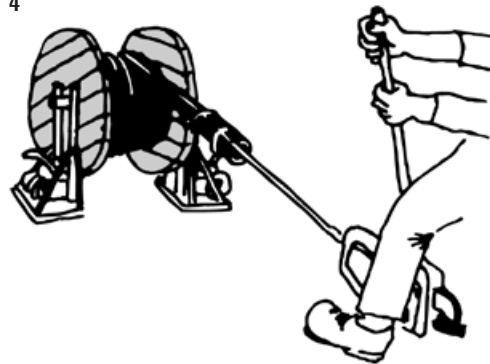

For large diameters or longer pipes, it may be necessary to use a simple hand-jack. If necessary, a deflection pulley can also be used. If you are using a motorized jack or tractor, ensure that the pulling speed does not exceed 1 ft/s.



**Caution:** When untying the end of the pipe from the reel or ring. The pipe is under considerable natural tension.



When unreeling pipe maintain the reel under tension. If the reel is allowed to turn freely the pipe may jump from the reel in loops and buckle. Secure reel after removing a section of pipe.



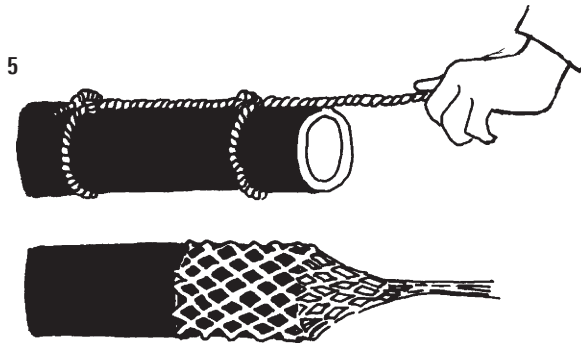

# Installation instructions

## Installing SECON-X®



If you are working with a steel traction cable, use an end-piece made of hemp or nylon and tie an offset double knot. If there is a risk of the tied end to jam, use a cable stocking. These can be purchased from our company.

 At all times during laying, the pipe ends must be protected in such a way that dirt and moisture are unable to penetrate. Beware of sharpe edges.

 Pipe cutting operations can generate dust or cutting chips that irritate skin and eyes. Operators should wear heavy clothing, including long-sleeve shirts, that protect the skin. Eye protection is also required. Use working gloves to protect skin from sharpe edges (burrs).

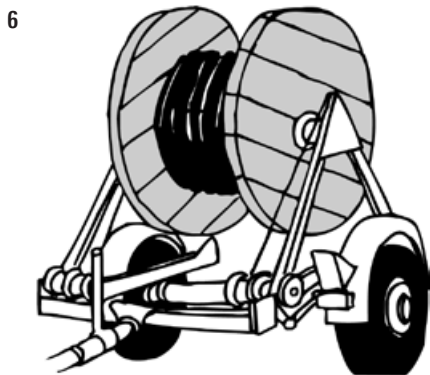

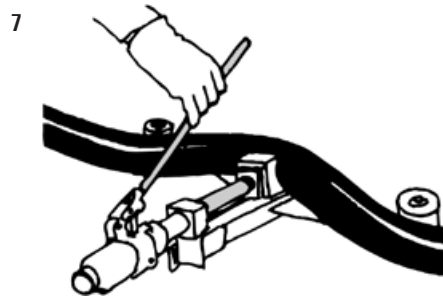

For large pipe diameters or longer sections of pipe, it is best to use a cable-laying trailer. We recommend to contact an electric cable laying company in your area.

## Bending the SECON-X®

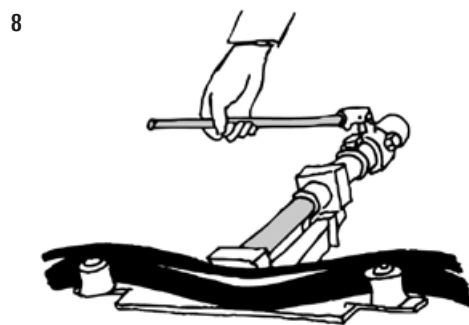

Pipes sizes up to 1 1/2" can be bent by hand. When laying SECON-X® 2" and bigger, it is advisable to use a bending machine, particularly if the pipes are to be laid in a building, channel or conduit.



 If possible, narrow bending radii should be avoided. Radii which are too narrow make your work more difficult and, at worst, may damage the pipe. The following guidelines should be observed:

**Table 1 Bending radii**

Type	Minimum bending radius	Recommended bending radius when laying in the ground
SEC 1"	18	35
SEC 1 1/2"	24	47
SEC 2"	30	59
SEC 3"	41	83

All dimensions in inch

Operating temperature SECON-X® Pipe is rated for -13 °F to +122 °F.

# Installation instructions

## Installing SECON-X®

### Installing the SECON-X® underground

Install all pipe with a continuous slope of at least 1/8" per foot toward the tank or the sump for vapor, vent, gravity fill, and suction supply lines. Support pipe sufficiently to avoid low points.

9

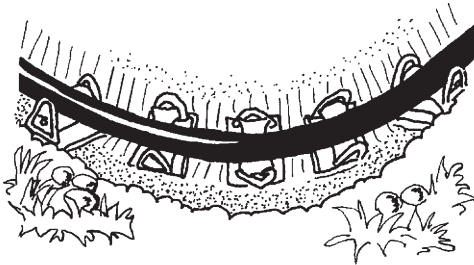

Cable rollers reduce friction and protect the pipe if it has to be laid around sharp corners. It makes work easier, particularly on stretches with a large number of curves.

In general, cable rollers are used by cable laying companies, and can be rented from them.

### Securing the SECON-X® Pipe

The SECON-X® Pipe can be installed and secured directly onto a flat surface of concrete, wood or other suitable material or by using Unistrut profiles. In either case it is recommended to use Unistrut "Cush-a-Clamp" clamps. See Table 3 for clamping distances.

**Table 3 Clamping distance**

Type	Pipe size	horizontal	vertical
SEC 1"	1"	47	55
SEC 1 ½"	1 ½"	60	70
SEC 2"	2"	65	70
SEC 3"	3"	75	90

All dimensions in inch



When installing SECON-X® Pipe in a trench, make sure that the pipe is at sufficient depth to protect it from surface traffic or other loads.

At a minimum a layer of sand or pea gravel of 4 inch below the pipe and 6 inch above the pipe should be maintained.

Decking slabs may be laid on top of the sand or gravel layer over the pipe to protect it from penetration from above.

The installation of a warning strip above the pipe is advisable.

### Above ground installation

When installed above ground SECON-X® Pipe must be protected from any damage due to traffic, pedestrian traffic, construction activity or any other activity that could impact, scrape, puncture or crush the pipe.

This is particularly true in public areas, where also intentional damage is possible.

# Marking

To identify abbreviations used for pipe markings, consult table 4.

**Pipe No. SECON-X® II, PS, 1 ½", 50 psig, MV-CT-HB-A&M-fuels  
"Underground Use Only", "Use Only OEM Fittings – Follow Installation Instructions"**

**Table 4**

Description	Marking
Pipe classification with date code	Pipe no. <sup>1</sup> (e.g. 12345)
Manufacturer name	BRUGG
Trade name	SECON-X® II
Type	SEC II
Integral primary/secondary system	PS
Nominal dimension	1 ½"
Nominal pressure	50 psig
Underground laying	Underground Use Only
OEM	Use Only OEM Fittings – Follow Installation Instructions
<b>Medium</b>	
Motor vehicles fuels	MV
Concentrated fuels	CT
High blend fuels	HB
Aviation and marine fuels	A&M-fuels

<sup>1</sup> Manufacturing date and manufacturing information of the material and manufactured article as well as all testings are traceable via the pipe number.

# Installation instructions – end fitting

## 1 End fitting components

- 1 SECON-X® pipe
- 2 Pressure ring
- 3 O ring
- 4 Thrust ring
- 5 Primary seal
- 6 Connector
- 7 Seal chamber ring
- 8 Screws M6



## 2 Supplied end fitting

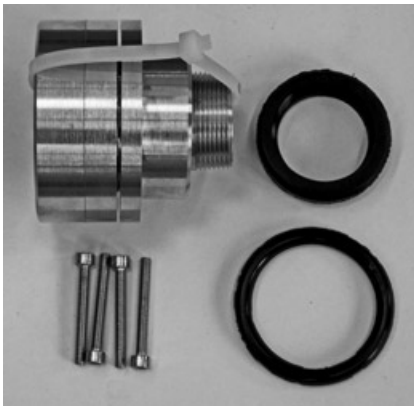

### SECON-X® end fitting

#### Connector (6) either:

- with NPT screw thread
- with EZ-Fit flange

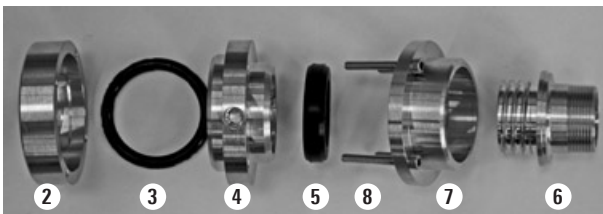

## 3 Installation tools

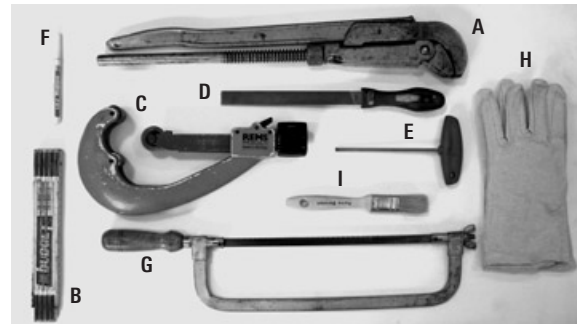

- A Pipe wrench
- B Folding rule
- C Pipe cutter
- D Smoothing file
- E Allen screw 3/16
- F Marker
- G Hacksaw
- H Gloves
- I Brush

# Installation instructions – end fitting

**4 Length of secondary pipe to be cut back**  
 Mark the length L to be cut back (1) acc. to the table below.

**Length L1:** Minimum secondary pipe length to cut back  
**Length L2:** Length of primary pipe protruding secondary

Pipe ID	$L_1 + 5$	$L_1 + 0.2$	$L_2 + X$	$L_2 + X$
	mm	inch		
1"	45	1.8	32 - 37	1.3 - 1.5
1 1/2"	50	2.0	37 - 43	1.5 - 1.7
2"	55	2.2	39 - 46	1.5 - 1.8
3"	75	3.0	56 - 68	2.2 - 2.7

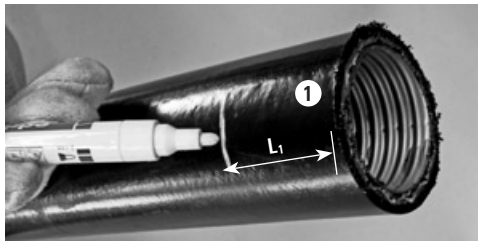

**5 Cutting through the secondary pipe**  
 Using the pipe cutter start cutting at the marked location. It can be clearly felt when the cutter passes from the LDPE layer to the PA, which is harder to cut. From that point continue taking care not to turn the secondary pipe piece with the pipe wrench. Repeat this step until the pipe piece can be turned. Mark this point on the pipe cutter for future use (this point varies depending on the pipe size).



**6 Removing the secondary pipe piece**  
 Remove the severed piece by turning it with the pipe wrench.



**7 Marking the exact length of primary pipe protruding from the secondary pipe**  
 Using the table to the left use the dimension  $L_2 + X$  to locate the start of the cut in the pipe valley.

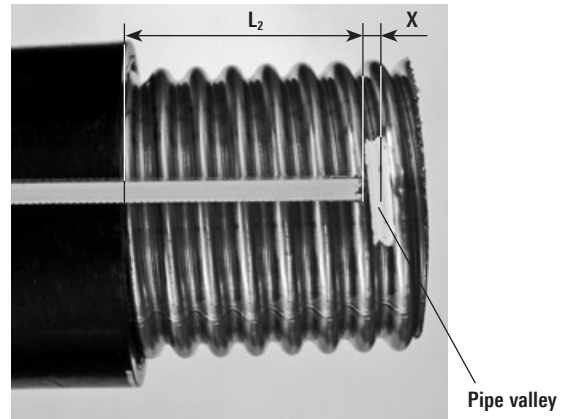

**8 Cutting the primary pipe to the exact length**  
 Thread the thrust ring (4) onto the pipe as shown. Use the thrust ring as guide to achieve a right angle cut. **If necessary file the cut smooth. Then remove the thrust ring.**

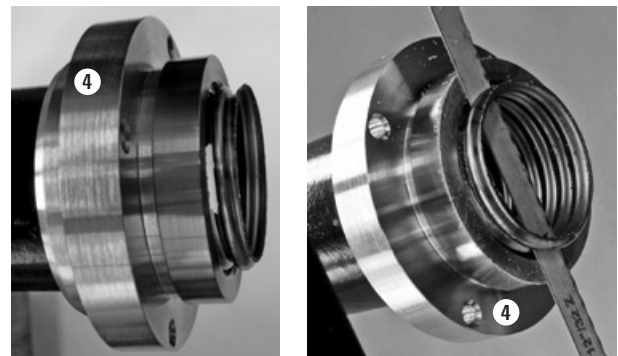

**9 Carefully debur the cut**  
 Make sure that the face of the cut is smooth throughout.



**10 Remove all filings**



# Installation instructions – end fitting

## 11 Sliding the pressure ring (2) onto the secondary pipe

Slide the pressure ring (2) onto the secondary pipe starting with the smaller opening.

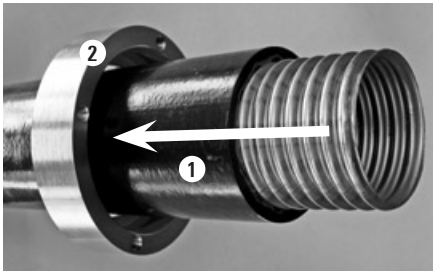

## 12 Fitting the O ring (3)

Wet the O ring (3) with water and slide it onto the secondary pipe (1).

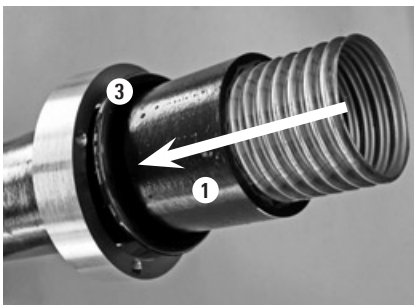

## 13 Threading the thrust ring (4) onto the primary pipe

Thread the thrust ring (4) onto the pipe starting with the larger diameter end until it stops against the secondary pipe.

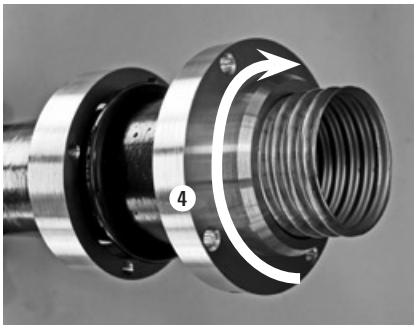

## 14 Installing the primary seal (5)

Moisten the primary seal (5) on the inside with water. Carefully thread the seal, with the threaded inside surface first, onto the end of the pipe until it stops against the ledge on the other side. Make sure not to deform the seal in the process.



## 15 Installing the connector (6)

Thread the connector (6) through the primary seal (5) corrugation while holding the seal to make sure the seal does not turn. Turn the connector gently until it rests against the seal without any visible space.

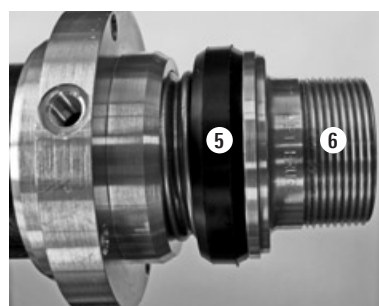

# Installation instructions – end fitting

## 16 Turning back the thrust ring (4)

Turn back the thrust (4) ring toward the primary seal (5) until no gap is visible.

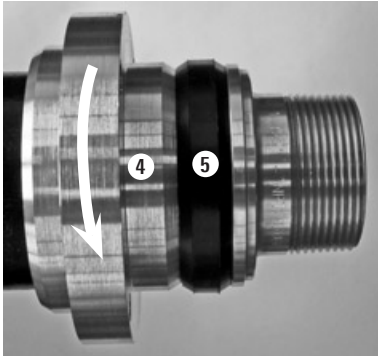

## 17 Installing the seal chamber ring (7)

Moisten the primary seal (5) with water on the outside. Slide the seal chamber ring (7) starting with the large outside diameter over the primary seal (5). Align the holes with the holes in the thrust ring (4). Insert the screws (8) into the holes.

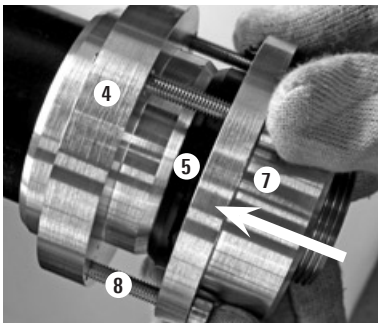

## 18 Returning the pressure ring (2) back into position

Align the threaded holes in the pressure ring (2) with the holes in the thrust ring (4) and slide the pressure ring over the O ring (3) up to the thrust ring. Turn the screws a few turns into the pressure ring.

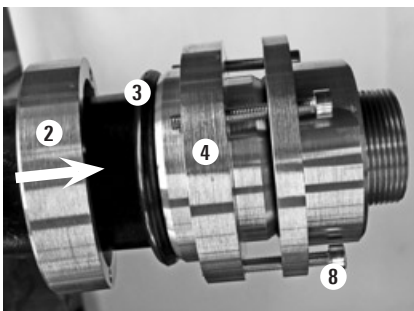

## 19 Tightening the end fitting assembly

**Always apply a copper based anti-seize lubricant before tightening.**

Evenly turn the screws until the gap between the thrust ring and the seal chamber ring is approximately 1/16".

**Make sure the bolts are evenly tightened to prevent any misalignment between the fitting components.**

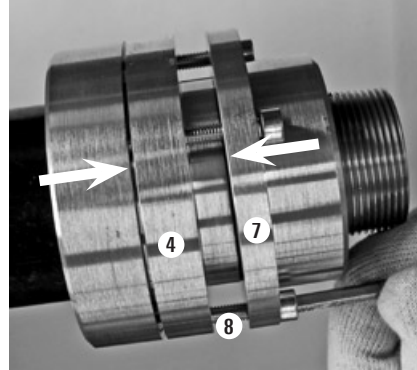

**\*\*ATTENTION\*\***

Maximum torque for  
1" fittings = 7.3 foot-pound

1 1/2" fittings and  
larger = 18.4 foot-pound

## 20 End fitting completely assembled

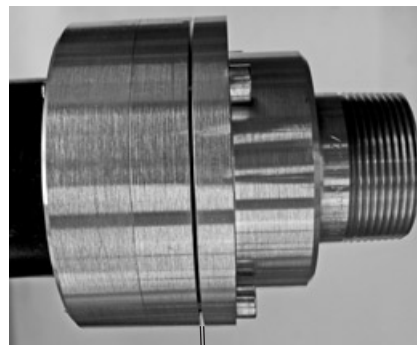

→ ← 1/16 of an inch

# Start of operation and maintenance

## Open and closed Secondary Containment Pipe System

### 1. Fuels

This pipe system is intended for the following fuels in accordance with UL 971 A regulations table 18.1:

Motor vehicle fuels:	MV
Concentrated fuels:	CT
High blend fuels:	HB
Aviation and marine fuels:	A&M

Where applicable the fuels have to follow the ASTM rules.

The material of construction of the integrated primary and secondary pipe system is 316L or 316Ti stainless steel.



**Caution:** The suitability of the material of construction of the SECON-X® Pipe for other fluids or media has to be investigated and verified.

### 2. Start of operations of the SECON-X® Pipe System

#### 2.1 Leak testing of the SECON-X® Pipe System

After installation of the pipe system a leak test has to be performed at a maximum pressure of  $100 \pm 10$  psig in the primary pipe and  $6 \pm 1$  psig in the interstitial space (annular gap between primary and secondary pipe). The test is to be performed with dry air or an inert gas.



**Caution:** Do not use any liquids or solid materials for the leak test.



**Caution:** The local rules and regulations for pressure testing have to be strictly adhered to.

#### 2.2 General operating instructions

The operator of a pipe system for flammable or hazardous liquids has to maintain such in proper operating condition and to operate it according to all applicable rules and regulations. The system has to be monitored constantly and necessary maintenance and repair work has to be performed immediately and, depending on the circumstances, appropriate safety measures have to be taken.



**Caution:** Product pipe may be under pressure after completion of testing.

The pipe system may not be operated, if it has deficiencies, which can endanger employees, other persons present or the environment. Appropriate steps have to be taken immediately to eliminate a dangerous condition.

The operator is obligated to issue the necessary orders, to take the necessary steps and to make sure such orders are adhered to avoid any dangerous conditions.

#### 2.3 Startup of the SECON-X® Pipe System



**Caution:** Startup and commissioning has to be performed in strict accordance with the local rules and regulations.

#### 2.4 Inspections by the operator

The operator inspects the pipe system in required intervals for proper operating condition in accordance with the operating instructions.

In particular he makes sure that,

1. fire protection installations are ready for service and that binder for spilled fluids is available in the specified quantity and at the predetermined location(s),
2. fire alarms are operational,
3. no prohibited materials and objects are located in areas with explosion hazards,
4. pipes and fittings are tight, procedure for testing of leaks in the interstitial space (annular gap between primary and secondary pipe) as described in point 2.1
5. the required safety installations are functioning,
6. fire lanes are unobstructed at all times
7. and in explosion hazardous areas bans of smoking and open fires are strictly observed.

#### 2.5 Maintenance of the SECON-X® Pipe System



**Caution:** Maintenance work and intervals have to be performed in accordance with the local regulations.

After completion of cleaning, maintenance and repair work and inspections the installation has to be returned to operating condition.

In particular all the safety devices have to be returned to operating condition.



# Start of operation and maintenance

## Open and closed Secondary Containment Pipe System

### 2.6 Shutdown and taking out of service of the SECON-X® Pipe System

Pipe systems, which are shut down, are to be secured in a such a way that they are no danger to employees or others.

Pipes, which are taken out of service temporarily, are to be emptied and cleaned in such a way that neither an explosive atmosphere exists nor can develop, and that no danger to the environment and groundwater can occur.

Pipes are to be secured against utilization. Leak detection systems and cathodic corrosion protection systems are to remain in operation.

### 2.7 Problems

If leakage or damage is detected in any part of the system (either by inspection of the sump, a leak detector, or similar monitors), the problems are to be immediately investigated by the site operator.

If leakage or damage to the piping system is verified, the manufacturer must be notified:

Manufacturer: BRUGG Pipesystems, LLC  
 Contact: P.O. Box 1836  
 Rome, GA 30162-1836  
 706.235.5606  
 pipesystems.na@brugg.com

### Open system

A secondary piping system with ends normally open at the sump and a minimum rated pressure of 5.0 psig (35 kPa) in accordance with UL 971 A regulations.

If a leaking fluid is detected, the operator is to immediately investigate whether the SECON-X® Pipe has a leak.

In case a leak is detected in the pipe, the pipe has to be shut down until the leak is repaired and a leak test to verify the successful repair is performed. Proceed according to point 2.1 for leak testing.



**Caution:** For the pressure test all local and otherwise relevant rules and regulations have to be observed.

### Closed, constantly monitored system

A closed system has to be monitored constantly by the installed monitoring system. If the monitoring system indicates a leak in the pipe, the pipe has to be shut down until the leak is repaired and a leak test to verify the successful repair is performed.



**Caution:** If a leak monitoring system is shut down, the leak tightness of the primary and secondary pipes of the SECON-X® Pipe system is no longer monitored. A possible leak will no longer be indicated. This means that, if a leak detection system is shut down, the entire pipe system has to be taken out of service.

Proceed according to point 2.1 for leakage testing. For an exact damage analysis it is applicable to pressurize the primary pipe with a maximum pressure of  $100 \pm 10$  psig.

# Standard Terms & Conditions of Sale

1. These Terms and Conditions will govern all sales by Brugg Pipesystems, LLC (hereinafter "Brugg" or "Seller") unless otherwise agreed to in writing, signed by Brugg at its home office in Rome, Georgia by an authorized agent. Terms and conditions contained in Buyer's purchase order or any other document that are different from or in addition to these Terms and Conditions are objected to and will not be binding on Brugg. Buyer will be deemed to have agreed to these Terms and Conditions by issuing a purchase order number and upon receipt from Brugg of a written acknowledgement of Buyer's placement of an order. Notwithstanding the foregoing, if Brugg, at Buyer's request, commences performance in any way prior to receipt by Buyer of Brugg's written acknowledgement, Buyer's acceptance of these Terms and Conditions will be deemed to have occurred on the date such performance commences.
2. All sales are made F.O.B. Rome, Georgia and each shipment or delivery shall be considered a separate and independent transaction. Buyer has risk of loss upon acceptance of shipment by a common carrier or truck man at the place of shipment. Freight costs will be prepaid and added to the invoice for reimbursement by Seller.
3. Shipping dates given in advance of actual shipment are estimated and deliveries will be made subject to prior orders on file with Seller and availability of products. Seller shall not be liable for failure to perform or delay in performance hereunder resulting from fire, labor difficulties, transportation difficulties, delays in usual sources of supply, major changes in economic conditions, commercial impracticability, or without limitation by the foregoing, cause beyond Seller's control.
4. If in Seller's sole judgment, the financial condition of Buyer at the time products are ready for shipment does not justify the terms of payment specified, Seller reserves the right to require full payment before shipment or delivery.
5. All sales are final. This contract may be canceled by Buyer only if agreed to by Seller in writing and upon payment of reasonable charges based upon expenses already incurred and commitments made by Seller.
6. **Seller shall not be liable for special, indirect, incidental or consequential damages.** The remedies of Buyer set forth herein are exclusive and the liability of Seller with respect to any contract or sale of anything done in connection therewith, whether in contract, tort, (including Seller's negligence), under any warranty or otherwise, shall not exceed the purchase price of the product or part on which such liability is based.
7. Unless otherwise agreed to in writing, the quoted price does not include freight or shipping costs or any sales, use or other taxes or charges payable to Federal, state or local authorities. Any such costs, taxes, or charges now or hereafter imposed with respect to sales or shipments hereunder will be added to such prices and Buyer agrees to pay, or reimburse Seller, for any such costs, taxes, or charges.
8. Net payment shall be due within 30 days from date of invoice unless otherwise agreed in writing by Seller. Any invoice not paid in full within such time will be deemed overdue. All invoices are payable in United States dollars. Checks are accepted subject to collection and the date of collection shall be deemed the date of payment. Any check or remittance received from or on account of Buyer may be accepted and applied by Seller against any indebtedness or obligation owing by Buyer, as shown on the books and records of Seller, without prejudice to the discharge of the remainder of any such indebtedness or obligations, regardless of any condition, proviso, statement, legend or notation appearing on, referring to, or accompanying said check or remittance. Should Buyer fail to make any timely payment, Seller may declare all outstanding invoices of Buyer immediately due and payable and Seller may cancel any outstanding purchase order issued by Buyer.
9. No sales representative or distributor of Seller has authority to alter, vary, or waive any of the foregoing standard terms and conditions stated herein.
10. Except as otherwise expressly provided herein, Buyer agrees that any claim of any kind by Buyer based on or arising out of this contract or otherwise shall be barred unless asserted by Buyer by the commencement of legal action within 12 months after the delivery of the products or other event, action or inaction to which such claim relates. This provision shall survive any termination of this contract, however arising.
11. Buyer shall pay interest to Seller on overdue invoices at the rate of 1.5 % per month on the unpaid portion.
12. Should Seller employ professional collection agents or attorneys to effect payment of monies due under this contract or related to the sale of goods by Seller to Buyer, all costs incident to said collection, including but not limited to court costs and reasonable attorney's fees of 15% of the total unpaid contract price, or in such amount as determined by the court to be reasonable, will be borne by Buyer.
13. This instrument and any signed acknowledgments issued by Brugg constitute the entire and only agreement between the parties hereto, and any representation, affirmation of fact, course of prior dealing, promise or condition in connection therewith or usage of the trade not specifically incorporated herein shall not be binding on either party. No waiver, alteration, or modification of any of the provisions hereof shall be binding unless in writing and signed by a specifically authorized representative of Seller.
14. **EXCLUSIVE WARRANTY:** Brugg warrants to the Buyer that the pipes and fittings sold by Brugg hereunder are warranted to be free from defects in materials and workmanship for a period of thirty (30) years for underground installations, a period of fifteen (15) years for above ground installations, and a period of five (5) years for marina installations. The warranty periods set forth above shall commence on the date of shipment to Buyer. BRUGG'S SOLE AND EXCLUSIVE OBLIGATIONS AND LIABILITIES UNDER THESE EXCLUSIVE WARRANTIES ARE AND SHALL BE LIMITED TO ISSUANCE OF CREDIT FOR OR REPAIR OR REPLACEMENT OF ANY PIPES OR FITTINGS OR PARTS THEREOF WHICH ARE PROVED TO BE OTHER THAN AS WARRANTED, AND BRUGG SHALL HAVE SOLE DISCRETION AS TO WHICH OF THESE REMEDIES IT SHALL PROVIDE. BRUGG SHALL NOT REIMBURSE OR MAKE ANY ALLOWANCE TO A BUYER FOR ANY LABOR OR SHIPPING CHARGES INCURRED BY THAT BUYER FOR REPLACEMENT, ADJUSTMENT, OR REPAIR OF ANY GOODS OR PARTS THEREOF OR FOR ANY OTHER WORK UNLESS SUCH CHARGES ARE AUTHORIZED IN ADVANCE BY BRUGG. ANY PIPES OR FITTINGS WHICH BRUGG DECIDES TO REPAIR OR REPLACE ARE WARRANTED TO BE FREE FROM DEFECTS IN MATERIALS AND WORKMANSHIP FOR THE REMAINDER OF THE INITIAL WARRANTY PERIOD SET FORTH ABOVE.
  - (a) If any of the pipes and fittings ("goods") on which Brugg warranties have not expired are claimed to be defective in material or workmanship, Brugg shall either examine the goods where they are located or, in its sole discretion, issue shipping instruction for return of the goods or any defective parts thereof, if any goods or parts thereof are returned to Brugg, the Buyer shall prepay all transportation charges for such return.
  - (b) Any claim for breach of Brugg's warranties shall conclusively be deemed to be waived unless written notice of such claim is given to Brugg within thirty (30) days after the date on which the claimed defect is discovered or should have been discovered.
  - (c) Brugg's warranties shall be considered null and void if the original Buyer for use transfers ownership of the warranted goods, unless Brugg receives notification in writing providing the name and address of the new owner by no later than fifteen (15) days after the date on which the transfer is made.
  - (d) Brugg's warranties for all marina applications shall be considered null and void if a Quotation Processing form is not completed by the Buyer and approved in writing by Brugg prior to installation of the goods.
  - (e) Brugg's warranties shall not apply to any goods or parts thereof which are obtained from manufacturers other than Brugg and resold by Brugg. Further, these warranties shall not apply to any goods or parts thereof which have been subjected to any misuses, neglect or accidental damage or which contain defects which are in any way attributable to improper transit, installation, or to alterations or repairs made or performed by any person or entity not under the control of Brugg and further conditioned upon the following:
    - Prior to installation, the goods were properly stored and were not subject to abuse or shipping damages;
    - The installation of the goods is performed in accordance with all applicable federal, state, local, and administrative rules and regulations;
    - Brugg's timely receipt of a written claim under this warranty by Buyer as set forth above;
    - Only fuels specified by UL971A or otherwise approved in writing by Brugg are used in the goods; and
    - The goods are installed by Brugg certified installers in accordance with the valid installation instructions issued by Brugg, which were in effect at the time the goods are installed, and the goods are operated, monitored, serviced, maintenance, and repaired in accordance with all applicable federal, state, local, and administrative rules and regulations.
  - (f) THE WARRANTIES SET FORTH HEREIN ARE THE SOLE AND EXCLUSIVE WARRANTIES FOR OR RELATING TO THE GOODS. BRUGG NEITHER MAKES NOR ASSUMES ANY WARRANTY OF MERCHANTABILITY, ANY WARRANTY OF FITNESS FOR ANY PARTICULAR PURPOSE, ANY WARRANTY THAT THE GOODS SHALL BE DELIVERED FREE OF THE RIGHTFUL CLAIM OF ANY THIRD PERSON BY WAY OF INFRINGEMENT OR THE LIKE, OR ANY OTHER WARRANTY OF ANY KIND, EXPRESS, IMPLIED, OR STATUTORY. BRUGG NEITHER ASSUMES NOR AUTHORIZES ANY PERSON OR ENTITY TO ASSUME FOR IT ANY OTHER LIABILITY OR OBLIGATION IN CONNECTION WITH THE SALE OR USE OF THE GOODS, AND THERE ARE NO ORAL AGREEMENTS OR WARRANTIES COLLATERAL TO OR AFFECTING THE SALE OF THE GOODS.
  - (g) BRUGG'S WARRANTIES, OBLIGATIONS AND LIABILITIES AND BUYER'S REMEDIES SET FORTH HEREIN ARE LIMITED TO THEIR PRECISE TERMS. BRUGG SHALL NOT BE LIABLE FOR ANY DAMAGES OF ANY KIND, INCLUDING, WITHOUT LIMITATION, SPECIAL, INCIDENTAL, OR CONSEQUENTIAL DAMAGES, FOR, RESULTING FROM OR IN CONNECTION WITH ANY BREACH OF WARRANTY. THE OBLIGATIONS AND LIABILITIES OF SELLER AND THE REMEDIES OF BUYER SET FORTH HEREIN SHALL BE THE BUYER'S SOLE AND EXCLUSIVE REMEDIES FOR, RESULTING FROM OR IN CONNECTION WITH BRUGG'S WARRANTIES OR ANY BREACH THEREOF.
15. The foregoing warranty will not cover and Brugg makes no warranties with respect to any goods subjected to abuse, misuse, misapplication, neglect, alteration or accident; to improper and incorrect installation or maintenance; or to abnormal conditions of use, temperature, moisture, dirt or corrosive matter; and any materials, parts, goods or other components that are manufactured by someone other than Brugg.
 

THE FOREGOING WARRANTY IS EXCLUSIVE AND IN LIEU OF ALL OTHER WARRANTIES, WHETHER EXPRESS, IMPLIED OR OTHERWISE ARISING BY OPERATION OF LAW, TRADE, USAGE OR COURSE OF DEALING, INCLUDING, WITHOUT LIMITATION, THE IMPLIED WARRANTIES OF MERCHANTABILITY AND FITNESS FOR A PARTICULAR PURPOSE.

Buyer agrees to provide Brugg with written notice of any breach of the above warranty within thirty days after Buyer discovers, or should have discovered, the alleged breach. Time is of the essence herein, and Buyer's failure to provide written notice to Brugg within the required time of any alleged breach of the foregoing warranty will release and discharge Brugg from any obligation or liability for that breach of warranty. The foregoing warranty extends only to Buyer and to no other person.
16. All products should be inspected thoroughly upon receipt. Claims of defect must be asserted by Buyer by written notice to Seller within thirty days of receipt. Buyer will be deemed to be in receipt of products if delivered to Buyer or to the ship to address designated by Buyer in the purchase order. Failure to give Seller notice of any claim within 30 days of receipt of the materials concerned shall constitute a waiver of such claim by the Buyer. Any request for return for replacement, repair, or credit must be made in writing to the Seller at Rome, Georgia within this time period.
17. No returns will be allowed unless the Seller has given prior written authorization from Rome, Georgia. Authorized returns must be carefully identified and tagged with quantity and reason for return. All unauthorized returns will be shipped back to the sender by collect freight with no action taken.
18. The validity and construction of this contract shall be determined under the laws of the State of Georgia. Should any provision be held void or unenforceable for any reason, all remaining provisions hereof remain in full force and effect.
19. The parties consent to the jurisdiction of the Superior Court of Floyd County, Georgia, the courts of Georgia, and the United States District Court for the Northern District of Georgia for all matters relating to or arising out of this contract.

# Pipe system expertise

without limits



International network  
[www.pipesystems.com](http://www.pipesystems.com)

## Your partner for pipe systems

We are just the people to contact if you are looking for efficient solutions for transporting liquids. Our project engineers, our development department, our in-house manufacturing systems and our professional installation team put us in a position to accompany your project in a competent and reliable way. Be it local or district heating, filling station construction, industrial system construction or building services engineering.

## Customer-specific solutions

BRUGG is the full service provider in the field of single-wall, double-wall and insulated pipe systems. This know-how allows us to manufacture project-specific customised items. Give us a call! Our engineers would be pleased to advise you and find a made-to-measure solution.

## International network

Our global partnership network can be reached on site at any time. More than 34 partners in 20 different countries will look after you wherever you are.

### BRUGG Rohrsysteme GmbH

Adolf-Oesterheld-Straße 31  
D-31515 Wunstorf  
phone +49 (0)5031 170-0  
fax +49 (0)5031 170-170  
[info@brugg.de](mailto:info@brugg.de)  
[www.brugg.de](http://www.brugg.de)

### BRUGG Pipesystems, LLC

P.O. Box 1836  
Rome, GA 30162-1836  
phone +1 (706) 235 5606  
fax +1 (706) 235 6035  
[pipesystems.na@brugg.com](mailto:pipesystems.na@brugg.com)  
[www.pipesystems.com](http://www.pipesystems.com)



A company of the BRUGG Group

**BRUGG** PIPESYSTEMS  
Flexible solutions