

Rovanco FRP Pipe System

For Temperatures to 210°F Below Ground

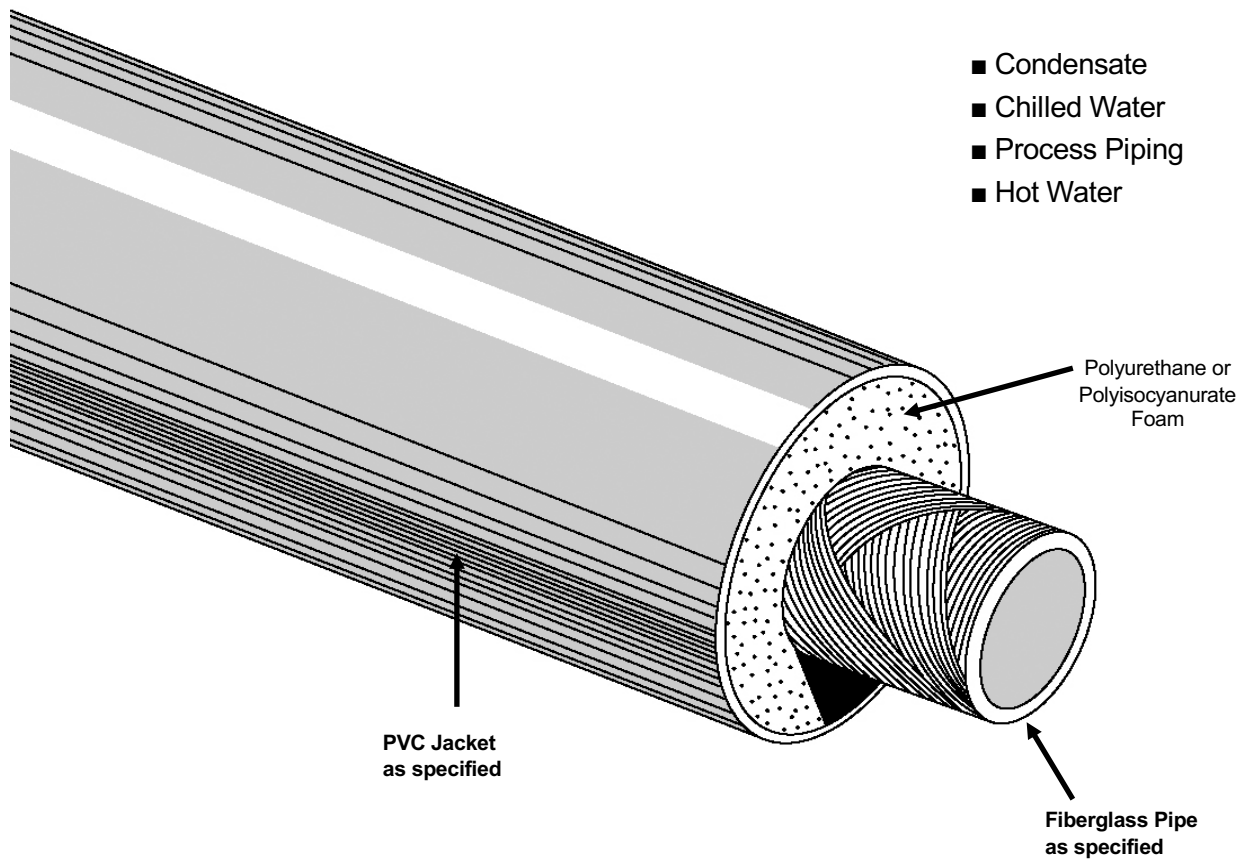

Rovanco's FRP System is designed for applications of pumped condensate, hot water, chill water, process line, etc. Carrier pipe insulation is either a polyurethane or polyisocyanurate high quality foam, combined with a durable PVC jacket supplied in 20' random lengths, means an economical, high-quality system.

Rovanco's FRP System is available with each end sealed for moisture protection and the joints are made with an epoxy resin.

Fittings are also made with an epoxy resin and thrust blocked in the field by the installer.

FRP comes complete with joint adhesive and fittings as required for the installation.

To find out more about Rovanco's FRP System, you can visit our factory, phone us (815) 741-6700, fax us (815) 741-4229, visit our website at www.rovanco.com or e-mail us at marketing@rovanco.com.

SPECIFICATION DATA SHEET

Fiberglass Piping System for Underground Condensate, Chilled Water, Process Piping and Hot Water Applications

Carrier Pipe:

Green Thread HP 16 bar filament wound fiberglass reinforced epoxy, bell and spigot, designed to withstand 230°F. ID of pipe shall contain a resin-rich liner. All 1" through 42 pipe to be in 20' random lengths. Pipe to be in conformance with ASTM D-2996.

Red Thread HP 16 pipe filament wound fiberglass reinforced epoxy, bell and spigot, designed to withstand 210°F. ID of pipe to be 20' random lengths. Pipe to be in conformance with ASTM D-2996.

* Bondstrand 3000A also available.

Polyurethane Insulation:

Insulation shall be a polyurethane foam injected with one shot into the annular space between carrier pipe and jacket. Insulation shall be rigid, minimum 90% closed cell polyurethane with a minimum 2.0 lbs per foot³ density, compressive strength of 30 psi @ 75°F and a thermal conductivity K factor no higher than 0.180 @ 75°F per ASTM C-518. Maximum operating temperature of urethane foam shall not exceed 250°F.

Polyisocyanurate Insulation:

Insulation shall be a polyisocyanurate foam injected with one shot into the annular space between carrier pipe and jacket. Insulation shall be rigid, >90% closed cell polyisocyanurate with a minimum 2.0 lbs per foot³ density, compressive strength of 30 psi @ 75°F, a thermal conductivity K factor no higher than 0.121 @ 75°F per ASTM C-518 and an E84 25/50 passive fire resistance rating. Maximum continuous operating temperature of polyisocyanurate foam shall not exceed 300°F. Also available in a 400°F polyisocyanurate foam.

Jacketing Material:

High impact, seamless Polyvinylchloride (PVC) Class 12454-B compound to ASTM 1784, Type 1, Grade 1, through 16" diameter. No FRP jacketing will be allowed. Minimum jacket thickness shall be in accordance with Table 1.

Table 1:

Nominal Pipe Size In Inches	Carrier Wall Thickness In Inches	Minimum Insulation Thickness In Inches	Jacket Size In Inches	Jacket Thickness In Mils
2	.140	1.81	6	70
3	.140	1.25	6	70
4	.180	1.75	8	80
6	.180	1.68	10	100
8	.200	1.68	12	120
10	.200	1.64	14	140
12	.200	1.46	16	160
14	.200	2.00	18	180
16	.206	2.00	20	200

* Larger sizes are also available upon request.

Joining Method:

Pipe and Fittings will be joined using a thermosetting epoxy resin. Mechanical Joints or O-Ring seal will not be allowed. Coupling joints and fittings will be un-insulated.

Fittings:

All fittings will be filament wound, heavy duty, bell & spigot type with a .020 interior liner in conformance with MIL-P28584A and MIL-P22245A. 90° elbows will be long radius only. All fittings will be un-insulated to permit proper thrust blocking.

End Seal:

Each length of pre-insulated pipe will be fitted with a watertight mastic end seal at jacket and pipe surfaces. All field cuts will be sealed with a field applied end seal. For non-insulated joints, the end seals shall have a letter of certification from an independent Testing Laboratory that they have been tested and proved watertight under the following test criteria:

Casing and End Seal testing Certification: Test and certification procedure shall demonstrate that casing, factory and field applied end seal are capable of resisting penetration of water into the casing and insulation at 20 feet of head pressure, measured above the highest point of the test sample, subjected over the entire surface of an 8 foot casing test sample for not less than 48 hours.

Anchors:

FRP pipe should be joined to steel systems with flanges. All steel systems should be anchored within five feet of connection point to eliminate any thrust, stress, or torque from the steel pipe being transferred to the FRP. Steel flanges should be 150# flat faced.

Thrust Blocks:

All changes in directions will be poured in concrete thrust blocks to provide anchor points and to direct expansion and contraction.

Backfill:

Should be tampered compactly in place so as to assure a stable surface. No rock shall be used in the first foot of backfill. 24 inches, top of pipe to grade, of compacted fill shall meet H-20 Highway loading.

Manufacturer's Assistance:

Rovanco will provide a field service man on-site to properly train the installing personnel in all phases of installation. (if required).

Approved Vendors:

FRP Pipe Systems by Rovanco, Joliet, Illinois or approved, ISO certified, equal. Any alternate supplier must submit their technical data to the engineer ten days prior to bid date to be approved in writing as an equal.

cc #06012023

Copyright 2023 – Rovanco's products are covered by various U.S. patents. Rovanco & Insul-8 are federally registered trademarks.

Contact Rovanco® for the name of your local Representative

20535 S.E. Frontage Road • Joliet, Illinois 60431 • (815) 741-6700

Website: www.rovanco.com • E-mail: marketing@rovanco.com

This is a generic product datasheet and is not intended for submittal use.