

CROSS SECTION X-X  
 ROUND ANCHOR 1/2" THICK

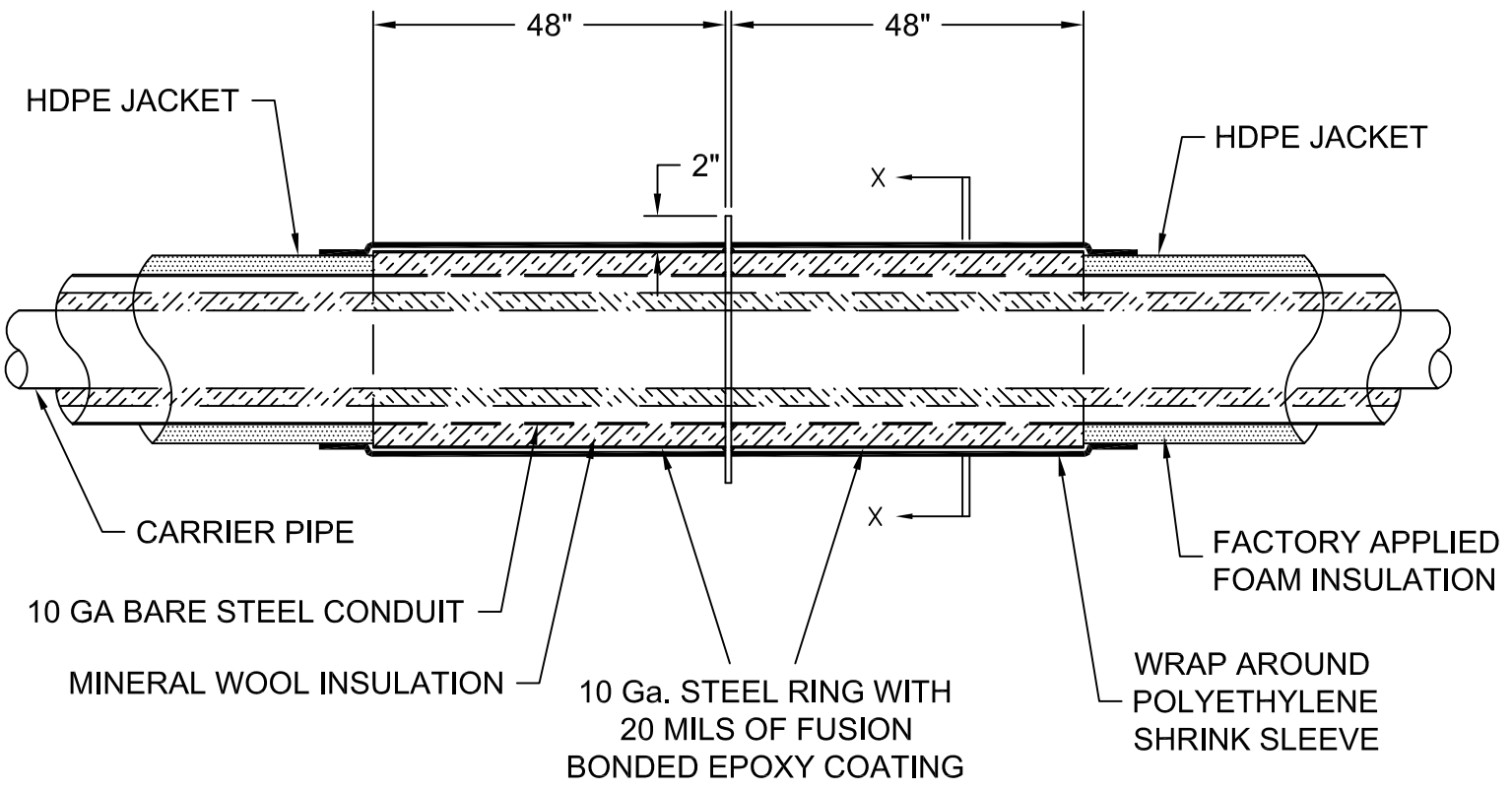

INSUL-800 ANCHOR DETAIL

N.T.S.

DESCRIPTION: INSUL-800 ANCHOR DETAIL

DRAWN BY: AMK	APPR. BY:
DATE/REV: 07/13/09	DWG. NO: 18A-02

**Rovanco**®

20535 S.E. FRONTAGE RD. JOLIET, IL. 60431 (815) 741-6700