

CROSS SECTION X-X
ROUND ANCHOR 1/2" THICK

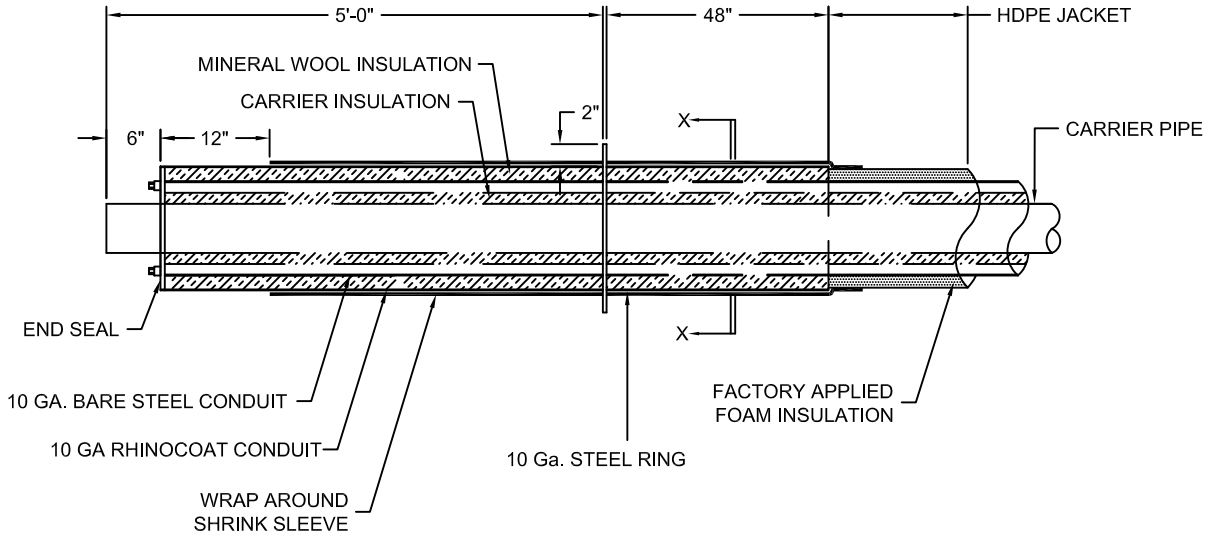

INSUL-800 ANCHOR DETAIL WITH END SEAL

N.T.S.

DESCRIPTION: INSUL-800 ANCHOR DETAIL WITH END SEAL

DRAWN BY:
AMK

APPR. BY:

DATE/REV:
07/14/05

DWG. NO:
18A-01

Rovanco®

20535 S.E. FRONTAGE RD. JOLIET, IL. 60431 (815) 741-6700